

## Hybrid PID and Advanced Algorithm-Based Control for Enhanced Active Suspension Performance

Sambhrant Srivastava<sup>1,\*</sup>, Vijay Kumar<sup>2</sup>, Harvinder Singh<sup>3</sup>, Rajwinder Singh<sup>4</sup>, V. Ashok<sup>5</sup>, Mika Sillanpää<sup>6</sup>

<sup>1,2</sup>Department of Mechanical Engineering, Rajkiya Engineering College, Azamgarh, Uttar Pradesh, India.

<sup>3,4</sup>Department of Mechanical Engineering, Chandigarh Engineering Landran, Mohali, Punjab, India.

<sup>5</sup>Department of Robotics and Automation, Dhaanish Ahmed College of Engineering, Chennai, Tamil Nadu, India.

<sup>6</sup>Department of Chemical Engineering Technology, University of Johannesburg, Johannesburg, Gauteng, South Africa.

sambhrantsrivastava4@gmail.com<sup>1</sup>, vijayakgarg@gmail.com<sup>2</sup>, honey.17aug@gmail.com<sup>3</sup>, rajgill4u@gmail.com<sup>4</sup>, ashok@dhaanishchennai.in<sup>5</sup>, mikas@uj.ac.za<sup>6</sup>

\*Corresponding author

**Abstract:** This study provides a thorough assessment of active suspension control strategies, emphasising the efficacy of traditional PID control, a novel algorithm, and their combined implementation. The analysis evaluates system stability, vibration attenuation, displacement regulation, and acceleration response across diverse operating conditions, including white noise input. Results show that PID control effectively reduces vibration and maintains baseline performance stability in active suspension systems. The proposed new algorithm, on the other hand, shows better adaptability and dynamic response, especially in the presence of random disturbances. The new algorithm stands out because it cuts acceleration by 50%, demonstrating its effectiveness at reducing vehicle body vibration and making the ride more comfortable. The hybrid control method, which combines PID control with the new algorithm, gives the best overall performance, with better stability, reliability, and optimised displacement and acceleration characteristics. Comparative results show that the new algorithm improves both displacement and acceleration control beyond what PID alone can achieve, making it easier to handle across a wider range of driving situations. These results show how the proposed control strategy could transform active suspension systems, setting a new standard for vehicle dynamics and improving comfort, safety, and performance.

**Keywords:** Vehicle Dynamics; Passive Suspensions; Time-Domain Analysis; System Stability; Vibration Attenuation; Displacement Regulation; Suspension Systems; Driver-Selectable Tuning.

**Cite as:** S. Srivastava, V. Kumar, H. Singh, R. Singh, V. Ashok, and M. Sillanpää, “Hybrid PID and Advanced Algorithm-Based Control for Enhanced Active Suspension Performance,” *AVE Trends in Intelligent Applied Sciences*, vol. 1, no. 4, pp. 172–184, 2025.

**Journal Homepage:** <https://www.avepubs.com/user/journals/details/ATIAS>

**Received on:** 18/09/2024, **Revised on:** 15/11/2024, **Accepted on:** 07/02/2025, **Published on:** 15/12/2025

**DOI:** <https://doi.org/10.64091/ATIAS.2025.000247>

### 1. Introduction

The vehicle suspension system, comprising springs and shock absorbers, is vital for accommodating vehicle oscillation and connecting the vehicle to its wheels. Recent advancements in suspension system performance aim to enhance vehicle efficiency. Proposals for redesigned suspension systems have emerged, pushing the boundaries of elements to boost performance and

---

Copyright © 2025 S. Srivastava *et al.*, licensed to AVE Trends Publishing Company. This is an open access article distributed under [CC BY-NC-SA 4.0](https://creativecommons.org/licenses/by-nc-sa/4.0/), which allows unlimited use, distribution, and reproduction in any medium with proper attribution.

sophistication [16]. The suspension system significantly contributes to road holding, braking, driving pleasure, and safety, keeping the vehicle isolated from road disturbances and within acceptable deflection limits. The control method of a vehicle's suspension system is crucial for balancing ride comfort and handling. Suspension systems can be passive or active, with active systems utilising electronic components to adjust to real-time conditions [17] dynamically. Electronic control units process sensor data, enabling optimal performance through automatic or driver-selectable tuning [18]. Despite the benefits of improved comfort, handling, and traction, challenges include system complexity and potential cost implications.

Overall, advanced suspension control is essential for enhancing the driving experience by achieving a harmonious balance between comfort and performance [1]. Researchers explore passive, semi-active, and active suspension designs through MATLAB/Simulink analysis and experiments, seeking an optimal compromise to achieve maximum ride comfort and handling by controlling suspension forces [2]; [3]. MATLAB/Simulink models are being developed nowadays to analyse the dynamic behaviour of a passive suspension system for a lightweight electric vehicle, based on a two-degrees-of-freedom quarter-car model.

The model's frequency responses align closely with theoretical calculations, indicating its potential for extension to a full vehicle model for designing effective isolators against unwanted vibrations [4]. Utilising PID controllers with automatic feedback control in MATLAB/Simulink enables dynamic characterisation and visualisation, addressing stability concerns in electromechanical systems for efficient suspension [5]. The PID controller block diagram in Figure 1 is widely utilised as the most common controller in industrial applications [21].

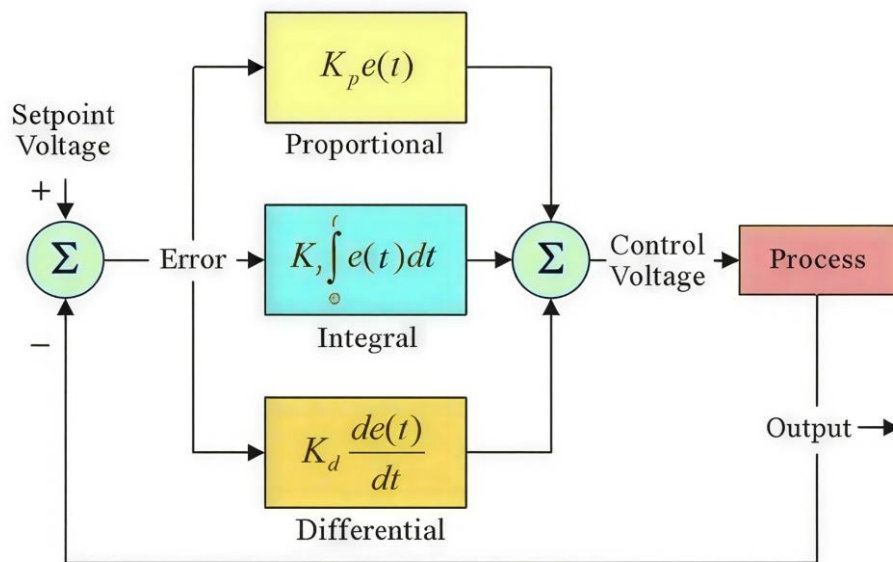

**Figure 1:** Block diagram from PID controller [6]

The mathematical form of the PID controller can be expressed as follows:

$$u(t) = K_p e(t) + K_i \int_0^t e(t) dt + K_d \frac{de(t)}{dt} \tag{1}$$

Where:

- **e(t):** Set point Plant Output
- **Kp:** Proportional Gain
- **Ki:** Internal Gain
- **Kd:** Derivative Gain

The vehicle's suspension system is pivotal for stability and ride comfort. Traditional passive suspension limitations prompted research into semi-active suspension, offering advantages in energy efficiency and improved comfort. This study establishes a 1/4-car semi-active suspension model, implements a PID control system, and validates the design through MATLAB/Simulink simulation, demonstrating its effectiveness [7].

The 1/4-car semi-active suspension model captures the vehicle's dynamic aspects, including tilting movements, body acceleration, suspension deflection, and tyre dynamic load. Its simplicity and minimal design parameters make it a widely studied choice for vibration control compared to complex vehicle models. Two degrees of Freedom 1/4-car semi-active suspension mode differential equations (2) are shown in Figure 2.

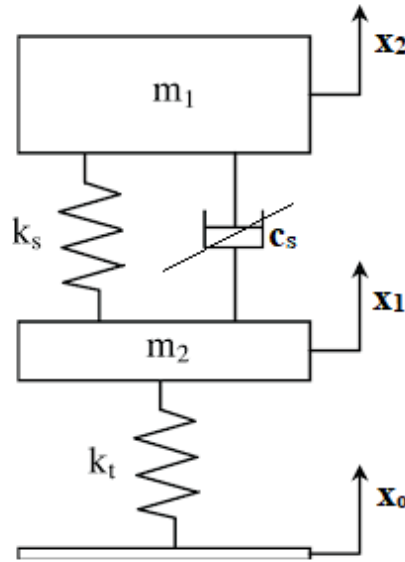

**Figure 2:** Two-degree-of-freedom 1/4-car semi-active suspension

$$m_2 \ddot{x}_2 + k_s(x_2 - x_1) + c_s(\dot{x}_2 - \dot{x}_1) + U = 0 \tag{2}$$

Where,  $m_1$ : non-suspension mass;  $m_2$  is the suspension mass;  $K_s$ : suspension spring stiffness;  $K_t$ : tyre stiffness;  $C_s$ : damper damping coefficient;  $X_0$  is the road roughness;  $X_1$  is the non-suspension mass displacement;  $X_2$ : Suspension mass displacement;  $U$ : adjustable damping force. A quarter-car suspension system using LQR, fuzzy logic control (FLC), and fuzzy-LQR algorithms achieved 84.2% improvement in body motion, 90% in car acceleration, 84.5% in suspension deflection, and 86.7% in tyre deflection, indicating substantial enhancements in ride comfort [8].

Robust control for indeterminate active car suspension systems using an input-lag approach is investigated, where a quarter-car model is transformed into a continuous-time system with state delay, incorporating polytopic parameter uncertainty to characterise actual uncertainties [9]. Widely adopted in business, PID control is known for its simplicity and versatility in managing diverse systems. Its ability to adjust critical parameters such as overshoot, rise time, and settling time contributes to its popularity.

However, PID's reliance on high loop gains makes it vulnerable to parameter fluctuations [10]. The role that active suspension components play in improving vehicle stability and ride quality is attracting significant attention [11]. Numerous control strategies have been investigated in this field, including the linear quadratic regulator, adaptive sliding control,  $H_\infty$  control, sliding control mode, fuzzy logic, preview control, optimal control, and neural network methods [12]. This study aims to assess the performance of active suspension systems in response to various road input signals, including unit-step, sine-wave, and white-noise signals [13]. The research will involve developing mathematical models for road inputs and active suspension control algorithms, followed by simulations in MATLAB/Simulink [14]. The objective is to compare the outcomes of passive and active suspension systems under different control strategies and road conditions [15].

## 2. Mathematical Model

This stepwise breakdown illustrates the progression of the methodology, from the initial modelling of road inputs to the execution and analysis of simulations, as shown in Figure 3.

### 2.1. Road Input Modelling

- Develop mathematical models for unit-step, sine-wave, and white-noise signals.

- Utilise MATLAB/Simulink for simulating road inputs based on the mathematical models.

### 2.2. Active Suspension Control Algorithms

- Propose and implement three control algorithms: PID control, Pavement feedback control, and a novel algorithm.
- Rigorously regulate and optimise the parameters of the control algorithms.

### 2.3. Simulation Models

- Construct computer simulation models for both passive and active suspension systems.
- Integrate mathematical equations governing suspension forces into the simulation models.

### 2.4. System Combination

- Combine simulation models to create different sets of suspension simulation systems.
- Represents road input for passive and PID Control active suspension systems.

### 2.5. Simulation Execution

- Apply input parameters to the simulation systems.
- Execute simulations using MATLAB/Simulink.
- Analyse output curves qualitatively and quantitatively.

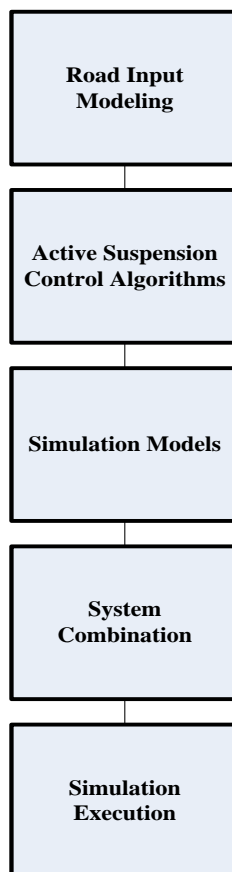

**Figure 3:** Flow chart of methodology for active suspension simulations in MATLAB

There is a tight relationship between the control system's design and its quality evaluation model, and the whole control design is dependent on the system's mathematical models [19]. The vehicle's body is represented by the sprung mass  $M_1$ , while the axle and wheel assembly is denoted by the unsprung mass  $M_2$ , in the vehicle dynamic model [20]. To ensure that the tyre makes

contact with the road surface when the vehicle is in motion, it is represented as a linear spring with a stiffness of  $k_2$ , as illustrated in Figure 4.

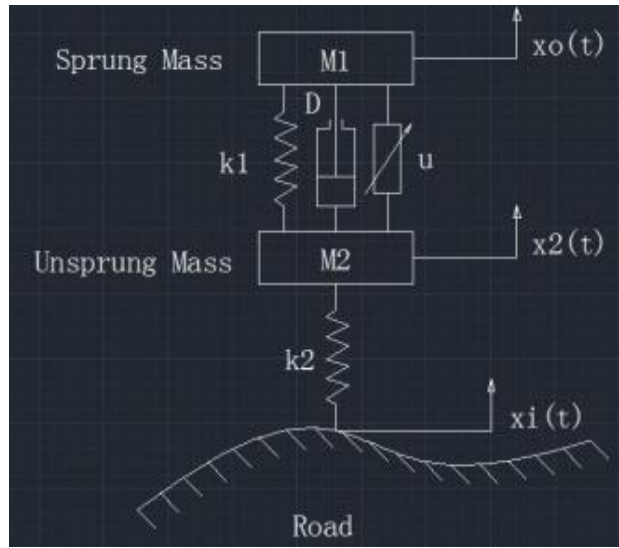

**Figure 4:** 1/4 active suspension system model with actuation force ( $u$ ) between springs [24]

As a whole, the suspension system's passive components are the linear damper ( $D$  for average damping coefficient) and the linear spring ( $k_1$  for average stiffness coefficient). The state variables  $x_0(t)$  and  $x_2(t)$  are the vertical displacements of the sprung and unsprung masses, respectively, and  $x_i(t)$  is the vertical road profile. The present model is analysed in the vehicle suspension system dynamics and establishes two degrees of freedom motion differential equations as shown:

$$m_2 \ddot{x}_2(t) - D[\dot{x}_0(t) - \dot{x}_2(t)] + k_1[x_2(t) - x_0(t)] + k_2[x_2(t) - x_i(t)] = -u \quad (3)$$

$$m_1 \ddot{x}_0(t) + D[\dot{x}_0(t) - \dot{x}_2(t)] + k_1[x_0(t) - x_2(t)] = u$$

Researchers can set:

$$x_1 = x_2(t), x_2 = x_0(t), x_3 = \dot{x}_2(t), x_4 = \dot{x}_0(t) \quad (4)$$

The system state space equation can be expressed as:

$$\frac{dX}{dt} = AX + BU \quad (5)$$

In this equation, state variable matrices are:

$$X = [x_1 \quad x_2 \quad x_3 \quad x_4]^T \quad (6)$$

Constant matrices  $A$  and  $B$  are shown below:

$$A = \begin{bmatrix} 0 & 0 & 1 & 0 \\ 0 & 0 & 0 & 1 \\ -\frac{k_1+k_2}{m_2} & \frac{k_1}{m_2} & -\frac{D}{m_2} & \frac{D}{m_2} \\ \frac{k_1}{m_1} & -\frac{k_1}{m_1} & \frac{D}{m_1} & -\frac{D}{m_1} \end{bmatrix} \quad (7)$$

$$B = \begin{bmatrix} 0 & 0 \\ 0 & 0 \\ \frac{k_2}{m_2} & \frac{1}{m_2} \\ 0 & -\frac{1}{m_1} \end{bmatrix} \quad (8)$$

The system input variable matrix is:

$$U = [x_i(t) \quad u]^T \quad (9)$$

The vehicle suspension system output matrix equation is:

$$Y = CX + DU \quad (10)$$

In the above equation, the output variable matrix Y is:

$$Y = \{k_2[x_i(t) - x_2(t)] \quad \dot{x}_0(t) \quad x_0(t)\} \quad (11)$$

Y can also be expressed as the following equation:

$$Y = \{k_2[x_i(t) - x_1] \quad \ddot{x}_2 \quad x_2\} \quad (12)$$

Constant matrices C and D are shown below:

$$C = \begin{bmatrix} -k & 0 & 0 & 0 \\ \frac{k}{m_1} & -\frac{k}{m_1} & \frac{D}{m_1} & -\frac{D}{m_1} \\ 0 & 1 & 0 & 0 \end{bmatrix} \quad (13)$$

$$D = \begin{bmatrix} k_2 & 0 \\ 0 & -\frac{1}{m_1} \\ 0 & 0 \end{bmatrix} \quad (14)$$

Various road signals, like step or sine inputs, are considered. However, at constant vehicle speed, road roughness follows a Gaussian distribution. It defies accurate mathematical description. The vehicle speed's power spectral density, a constant akin to white noise, can be easily converted into a road roughness time-domain model [22]. White noise is a random signal with equal intensity across frequencies, representing randomness [23]. Commonly used in simulations, it models random disturbances or fluctuations (Figure 5).

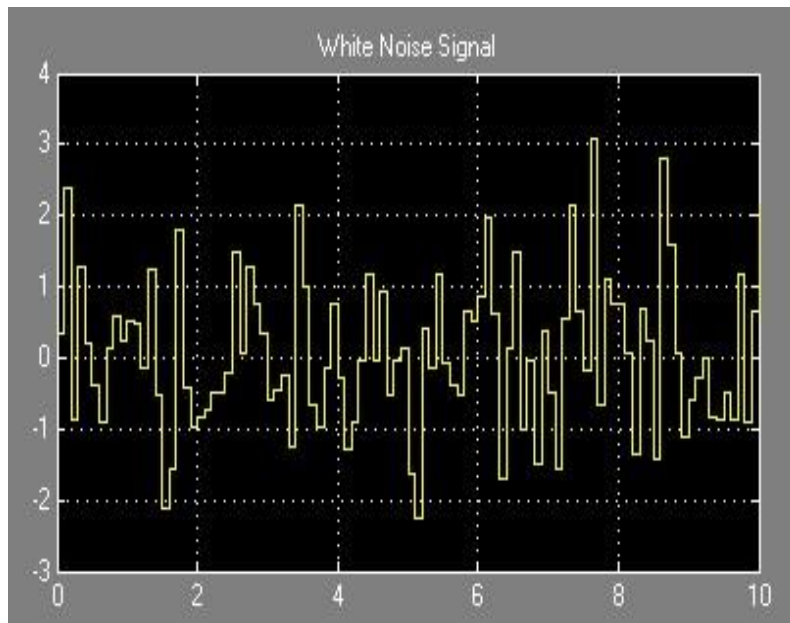

**Figure 5:** White noise input signal [24]

In accordance with the international standard ISO/TC108/SC2N67, the following equation defines the road surface vertical displacement power spectral density (PSD),  $G_q(n)$ :

$$G_q(n) = G_q(n_0) \left(\frac{n}{n_0}\right)^{-W} \quad (15)$$

Where 'n' is the spatial frequency, the reciprocal of the wavelength, unit  $m^{-1}$ ; 'n<sub>0</sub>' is the reference spatial frequency,  $n_0=0.1m^{-1}$ ; 'G<sub>q</sub>(n<sub>0</sub>)' is the road roughness coefficient, unit  $m^2/m^{-1}$ ; 'W' is the frequency index, which determines the road surface frequency spectrum structure, usually taking the frequency index  $W=2$ , considering the velocity when researchers input the road signal. Vehicle velocity 'v,' researchers can convert spatial frequency power spectral density G<sub>q</sub>(n) to time frequency power spectral density G<sub>q</sub>(f). When a vehicle drives through a section of road roughness, whose spatial frequency is n (unit  $m^{-1}$ ), and the vehicle velocity is v (unit is  $ms^{-1}$ ), the time frequency f (unit  $s^{-1}$ ) is the product of n and v:

$$f = n \times v \quad (16)$$

This is the relationship between the power spectral density at frequencies f and n over space:

$$G_q(f) = \frac{1}{v} G_q(n) \quad (17)$$

When  $W = 2$ , researchers have:

$$G_q(f) = \frac{1}{v} G_q(n_0) \left(\frac{n}{n_0}\right)^{-2} = \frac{G_q(n_0)n_0^2v}{f^2} \quad (18)$$

One of these is the white noise generating method, which stands out due to its straightforward physical meaning and computer-friendly nature:

$$\dot{q}(t) = -2\pi f_0 q(t) + 2\pi n_0 \sqrt{G_q(n_0)v} * w(t) \quad (19)$$

The equation states that the following variables are defined: q(t) is the random road input signal, f<sub>0</sub> is the filter-lower-cut-off frequency, G<sub>q</sub>(n<sub>0</sub>) is the road roughness coefficient in meters per square metre, and w(t) is the random white noise. By means of the Laplace transform:

$$\frac{q(s)}{w(s)} = \frac{2\pi n_0 \sqrt{G_q(n_0)v}}{s+2\pi f_0} \quad (20)$$

As may be seen in Table 1 [24], the worldwide standard specifies eight road levels, labelled A through H. The road's quality ranges from A (the best) to H (the worst).

**Table 1:** Eight degrees of road roughness

Road Level	$G_q(n_0)/(10^{-6}m^3)$ ( $n_0 = 0.1 m^{-1}$ )	$\sigma_q/(10^{-3} m)$ $0.011m^{-1} < n < 2.83m^{-1}$
	Geometric Average	Geometric Average
A	16	3.81
B	64	7.61
C	256	15.23
D	1024	30.45
E	4096	60.90
F	16384	121.80
G	65536	243.61
H	262144	487.22

The following form illustrates how the reference varies across various road levels. The three PID parameters identified are  $K_p = 10$ ,  $K_i = 0.1$ , and  $K_d = 0.1$ . The vehicle suspension model system input parameters are shown in Table 2.

**Table 2:** Vehicle suspension model system input parameters form

$m_1$ (Kg)	$m_2$ (Kg)	$K_t$ (N/m)	$K_s$ (N/m)	$D$ (Ns/m)
300	40	15000	150000	1000

### 3. Numerical Model

The novel algorithm redefines the active force generation for masses  $m_1$  and  $m_2$ , departing from traditional methods such as the sky-hook and ground-hook. It uniquely determines the variable ( $u$ ) by incorporating factors such as the relative positions of the body mass and the wheel, along with the body mass's movement speed, thereby optimising control and performance. Active force fitting formula:

$$u = -[l_1(x_o(t) - x_2(t)) + l_2 \frac{dx_o(t)}{dt}] \tag{21}$$

In the equation presented,  $u$  denotes the active force from an active actuator, with  $l_1$  and  $l_2$  as distinct coefficients tailored to each vehicle model. The quest for optimal active force involves identifying appropriate  $l_1$  and  $l_2$  coefficients through pavement monitoring. The fitting formula decomposes  $u$  into two segments: the first,  $-l_1[x_o(t)-x_2(t)]$ , mimics an extra-spring system, while the second,  $-l_2*dx_o(t)/dt$ , behaves as a damping system. This formulation conceptualises you as the resultant force from two active devices, promoting stability, straightforward control, and averting system divergence (Figure 6).

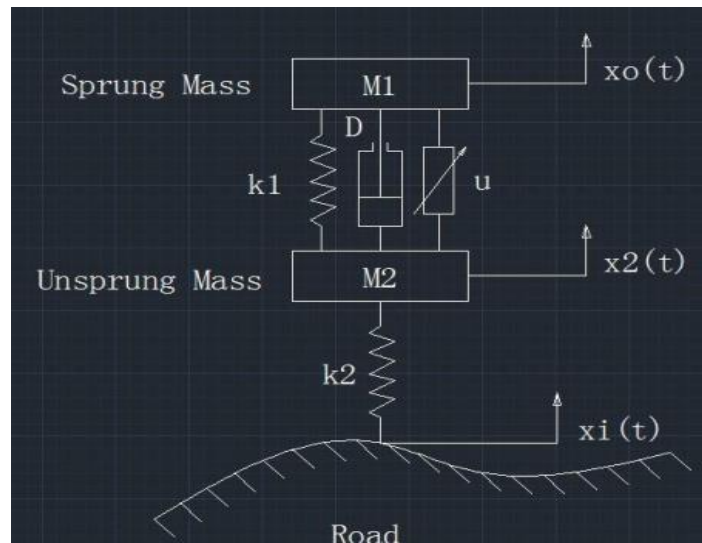

**Figure 6:** Modelling active suspension with actuating force ( $u$ ) between sprung and unsprung mass [24]

Relative position is ascertained through a displacement transducer, while velocity is gleaned from a velocity sensor (Figure 7).

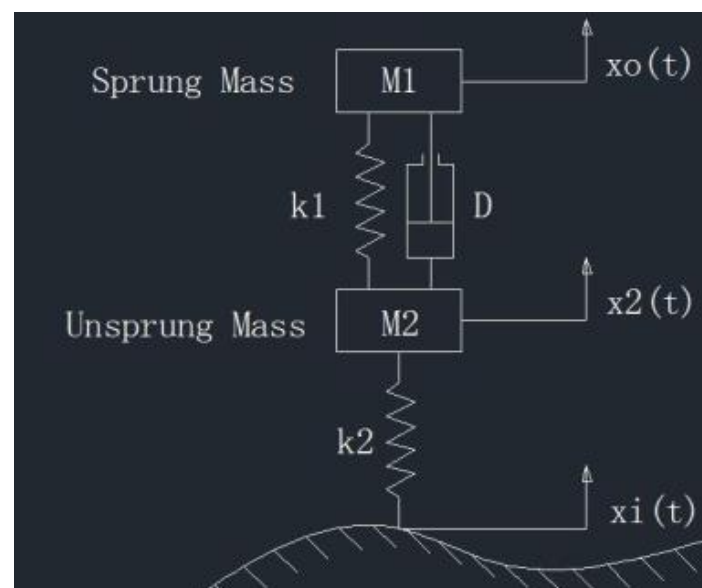

**Figure 7:** Math model of passive suspension system [24]



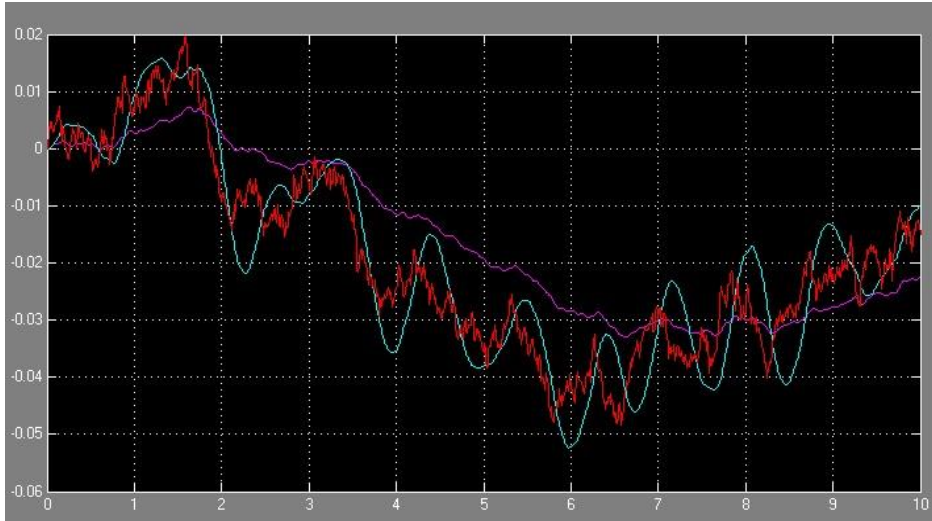

**Figure 10:** New algorithm compares active and passive suspension system output displacement time response with white noise signal input [24]

The absence of significant fluctuations in the curves underscores the stability of the system. Notably, this system achieves approximately a 50% reduction in acceleration, a factor that significantly contributes to its superior overall equipment effectiveness compared to the conventional pavement feedback system.

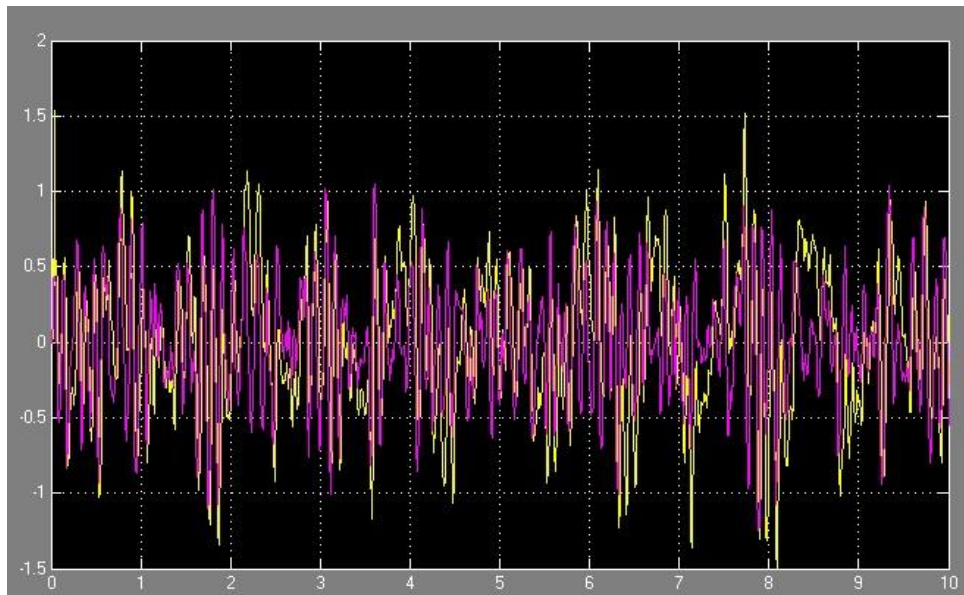

**Figure 11:** New algorithm compares active suspension system acceleration time response to passive suspension system with white noise signal input [24]

The implications of these findings are substantial, as they suggest that the new algorithm not only surpasses its predecessor but sets a new standard for active suspension control. Further advancements are evident compared to the PID-controlled active suspension system. The new PID control algorithm not only builds on the successes of its predecessor but also further refines the output displacement and acceleration. The flatter curves in Figures 12 and 13 indicate a smoother, more controlled response, highlighting the system's enhanced reliability and stability.

This improvement is particularly noteworthy as it addresses one of the challenges in active suspension systems—maintaining optimal performance across diverse driving conditions. The holistic evaluation of these results prompts a reflection on the evolving landscape of suspension control technology. The strides made by the new algorithm, both in isolation and in comparison to existing systems, underscore its potential to redefine the standards of performance and efficiency in vehicular suspension.

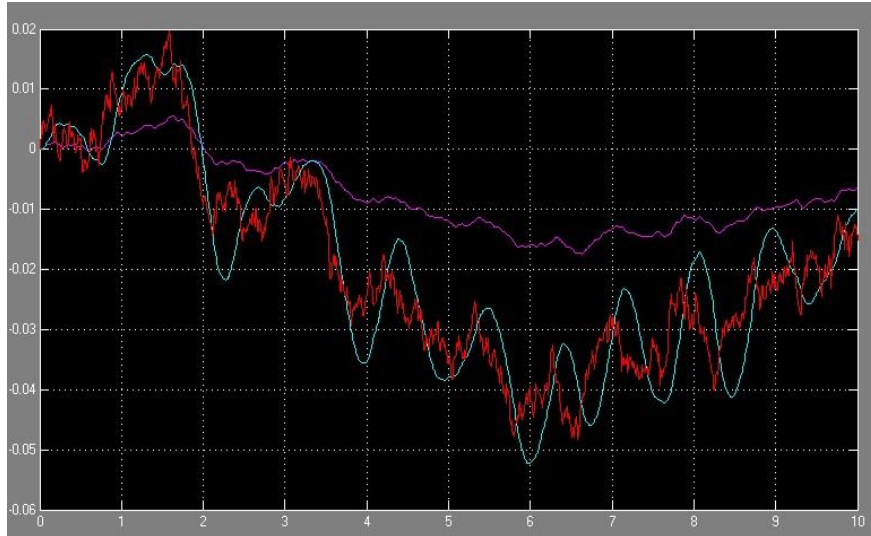

**Figure 12:** New algorithm PID control active suspension output displacement time response with white noise signal input compared to passive suspension [24]

As researchers enter a new era of automotive engineering, the continuous refinement of these control systems not only promises a more comfortable and secure driving experience but also opens the door to further innovation in vehicle dynamics.

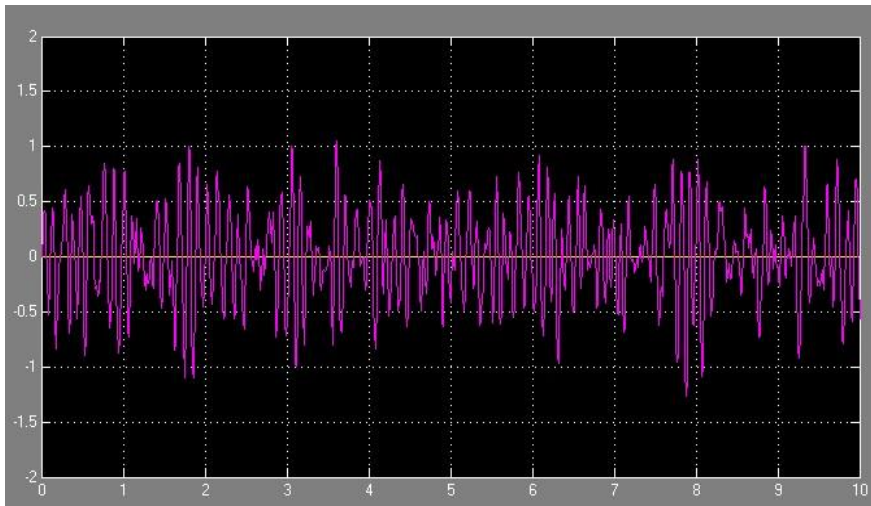

**Figure 13:** New PID algorithm takes white noise signal to control active suspension system output acceleration time response [24]

## 5. Conclusion

The study of active suspension control strategies shows that the tested methods exhibit very different levels of performance and effectiveness. The comparison shows that traditional PID control is a stable and reliable starting point for vehicle suspension systems. Still, its performance can be greatly improved when combined with the new control algorithm. The combined approach leverages the strengths and ease of PID control with the new algorithm's ability to adapt and optimise, making the system more stable, the ride more comfortable, and the vehicle easier to handle overall. The new algorithm stands out because it can independently reduce acceleration by a huge 50%, demonstrating that it is better at reducing vibration and making passengers more comfortable. It also improves displacement control, helping the car stay on the road better and move less when driving conditions change. Compared with traditional PID control, the new method consistently provides better dynamic response and disturbance rejection. These results show how the proposed algorithm could change the operation of active suspension systems. This method helps make vehicle dynamics and smart automotive control systems better by setting a higher standard for controlling displacement and acceleration. Overall, the results support using the new algorithm, either on its own or in combination with PID control, to advance next-generation active suspension technologies. In summary, analysing active

suspension control methods highlights their distinct strengths. Combining PID control with the new algorithm proves most effective, ensuring superior stability and reliability while enhancing displacement and acceleration characteristics. The new algorithm stands out with a 50% reduction in acceleration, demonstrating superior overall effectiveness. Comparisons with PID control reveal its capacity to refine displacement and acceleration. These findings underscore the transformative potential of the new algorithm, setting a new standard for active suspension control and contributing to the evolution of vehicle dynamics.

**Acknowledgement:** The authors would like to express their sincere gratitude to Rajkiya Engineering College, Chandigarh Engineering College, Dhaanish Ahmed College of Engineering and the University of Johannesburg for their valuable support, resources, and academic guidance throughout this research.

**Data Availability Statement:** This study employs a dataset incorporating hybrid PID and advanced algorithm-driven control parameters to improve active suspension system performance. The dataset can be made available by the corresponding author upon reasonable request, in accordance with applicable data-sharing guidelines.

**Funding Statement:** No grant supported this research.

**Conflicts of Interest Statement:** The authors declare that they have no conflicts of interest.

**Ethics and Consent Statement:** Ethical clearance for this study was obtained from the appropriate authority, and consent was obtained from the organisation and all individual participants before data collection.

## References

1. Y. Nan, S. Shao, C. Ren, K. Wu, Y. Cheng, and P. Zhou, "Simulation and Experimental Research on Active Suspension System with Time-Delay Feedback Control," *IEEE Access*, vol. 11, no. 8, pp. 88498–88510, 2023.
2. A. Goodarzi, Y. Lu, and A. Khajepour, "Vehicle suspension system technology and design," *Springer Nature*, Cham, Switzerland, 2023.
3. P. S. Karuppiah, P. Ganesan, P. S. Kasavan, and S. Sambasivam, "Experimental and simulation investigation of vertical response of stepped torsion bar spring for light motor vehicle suspension system," *ProcInst. Mech. Eng. Part D J. Automob. Eng.*, vol. 237, no. 7, pp. 1479–1488, 2023.
4. M. S. Jamali, K. A. Ismail, Z. Taha, and M. F. Aiman, "Development of Matlab Simulink model for dynamics analysis of passive suspension system for lightweight vehicle," *J. Phys. Conf. Ser.*, vol. 908, no. 1, p. 12066, 2017.
5. M. N. Mustafa, "Simulation of electromagnetic suspension functioning processes in the MATLAB/Simulink system," *J. Phys. Conf. Ser.*, vol. 2060, no. 1, p. 12028, 2021.
6. A. M. H. Al-Ghanim and A. A. Nassar, "Modeling, simulation, and control of half car suspension system using Matlab/Simulink," *Int. J. Sci. Res.*, vol. 7, no. 1, pp. 351–362, 2018.
7. M. Zeng and L. Ye, "Simulation analysis of vehicle suspension performance based on Simulink," in *proc. 2017 Int. Conf. Comput. Syst. Electron. Control. ICCSEC*, Dalian, China, 2017.
8. T. Abut and E. Salkim, "Control of Quarter-Car Active Suspension System Based on Optimized Fuzzy Linear Quadratic Regulator Control Method," *Appl. Sci.*, vol. 13, no. 15, p. 8802, 2023.
9. H. Gao, W. Sun, and P. Shi, "Robust Sampled-Data  $H_\infty$  Control for Vehicle Active Suspension Systems," *IEEE Trans. Control Syst. Technol.*, vol. 18, no. 1, pp. 238–245, 2009.
10. M. Najm, A. Younis, and F. Majeed, "Mathematical Modelling and PID Controller Implementation to Control Linear and Nonlinear Quarter Car Active Suspension," *Al-Rafidain Eng. J.*, vol. 28, no. 2, pp. 113–121, 2023.
11. Y. M. Sam, M. R. H. A. Ghani, and N. Ahmad, "LQR controller for active car suspension," in *2000 TENCON Proceedings. Intelligent Systems and Technologies for the New Millennium (Cat. No. 00CH37119)*, Kuala Lumpur, Malaysia, 2000.
12. P. C. Chen and A. C. Huang, "Adaptive sliding control of non-autonomous active suspension systems with time-varying loadings," *J. Sound Vib.*, vol. 282, no. 3–5, pp. 1119–1135, 2005.
13. H. Du and N. Zhang, " $H_\infty$  control of active vehicle suspensions with actuator time delay," *J. Sound Vib.*, vol. 301, no. 1–2, pp. 236–252, 2007.
14. H. F. Elbab, E. Allam, M. A. Hady, and S. Abouel-Seoud, "Performance of active suspension with fuzzy control," SAE Technical paper, *SAE International*, Warrendale, Pennsylvania, United States of America, 2009.
15. W. A. H. Oraby, M. A. Aly, S. M. El-Demerdash, and A. M. Selim, "Influence of active suspension preview control on the vehicle lateral dynamics," SAE Technical Paper, *SAE International*, Warrendale, Pennsylvania, United States of America, 2007.
16. J. Marzbanrad, G. Ahmadi, Y. Hojjat, and H. Zohoor, "Optimal active control of vehicle suspension system including time delay and preview for rough roads," *J. Vib. Control*, vol. 8, no. 7, pp. 967–991, 2002.

17. J. Marzbanrad, Y. Hojat, H. Zohour, and S. K. Nikravesh, "Optimal preview control design of an active suspension based on a full car model," *Scientia Iranica*, vol. 10, no. 1, pp. 23-36, 2003.
18. N. Al-Holou, T. Lahdhiri, D. S. Joo, J. Weaver, and F. Al-Abbas, "Sliding mode neural network inference fuzzy logic control for active suspension systems," *IEEE Trans. Fuzzy Syst.*, vol. 10, no. 2, pp. 234–246, 2002.
19. J. Wang, W. Wang, K. Atallah, and D. Howe, "Design of a linear permanent magnet motor for active vehicle suspension," in *2009 IEEE International Electric Machines and Drives Conference*, Miami, Florida, United States of America, 2009.
20. M. A. Nekoui and P. Hadavi, "Optimal control of an active suspension system," in *Proceedings of 14th International Power Electronics and Motion Control Conference EPE-PEMC*, Ohrid, Macedonia, 2010.
21. J. Sun and Q. Yang, "Compare and analysis of passive and active suspensions under random road excitation," in *2009 IEEE International Conference on Automation and Logistics*, Shenyang, China, 2009.
22. F. Feng, F. Huang, W. Wen, Z. Liu, and X. Liu, "Evaluating the dynamic response of the bridge-vehicle system considering random road roughness based on the moment method," *Adv. Civ. Eng.*, vol. 2021, no. 11, pp. 1–12, 2021.
23. T. Lenkutis, A. Čerškus, N. Šešok, A. Dzedzickis, and V. Bučinskas, "Road surface profile synthesis: Assessment of suitability for simulation," *Symmetry*, vol. 13, no. 1, p. 68, 2021.
24. Q. Zhou, "Research and Simulation on New Active Suspension Control System," *Lehigh Preserve Theses and Dissertations*, Lehigh University, Pennsylvania, USA, 2013, pp. 1–78.